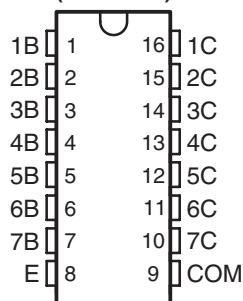

HIGH-VOLTAGE HIGH-CURRENT DARLINGTON TRANSISTOR ARRAYS

Check for Samples: [ULQ2003A-Q1](#), [ULQ2004A-Q1](#)

FEATURES

- Qualified for Automotive Applications
- ESD Protection Exceeds 200 V Using Machine Model (C = 200 pF, R = 0)
- 500-mA-Rated Collector Current (Single Output)
- High-Voltage Outputs: 50 V
- Output Clamp Diodes
- Inputs Compatible With Various Types of Logic
- Relay-Driver Applications

D OR PW PACKAGE
(TOP VIEW)

DESCRIPTION

The ULQ2003A and ULQ2004A are high-voltage high-current Darlington transistor arrays. Each consists of seven npn Darlington pairs that feature high-voltage outputs with common-cathode clamp diodes for switching inductive loads. The collector-current rating of a single Darlington pair is 500 mA. The Darlington pairs can be paralleled for higher current capability. Applications include relay drivers, hammer drivers, lamp drivers, display drivers (LED and gas discharge), line drivers, and logic buffers.

The ULQ2003A has a 2.7-k Ω series base resistor for each Darlington pair, for operation directly with TTL or 5-V CMOS devices. The ULQ2004A has a 10.5-k Ω series base resistor to allow operation directly from CMOS devices that use supply voltages of 6 V to 15 V. The required input current of the ULQ2004A is below that of the ULQ2003A.

ORDERING INFORMATION⁽¹⁾

T _A	PACKAGE ⁽²⁾	ORDERABLE PART NUMBER	TOP-SIDE MARKING	
-40°C to 105°C	SOIC – D	Tube of 40	ULQ2003ATDQ1	
		Reel of 2500	ULQ2003ATDRQ1	
	SOIC – D	Tube of 40	ULQ2004ATDQ1	Product Preview
		Reel of 2500	ULQ2004ATDRQ1	ULQ2004AT
-40°C to 125°C	TSSOP – PW	Reel of 2000	ULQ2003ATPWRQ1	U2003AT
	SOIC – D	Reel of 2500	ULQ2003AQDRQ1	ULQ2003AQ

(1) For the most current package and ordering information, see the Package Option Addendum at the end of this document, or see the TI web site at www.ti.com.

(2) Package drawings, thermal data, and symbolization are available at www.ti.com/packaging.



Please be aware that an important notice concerning availability, standard warranty, and use in critical applications of Texas Instruments semiconductor products and disclaimers thereto appears at the end of this data sheet.

LOGIC DIAGRAM

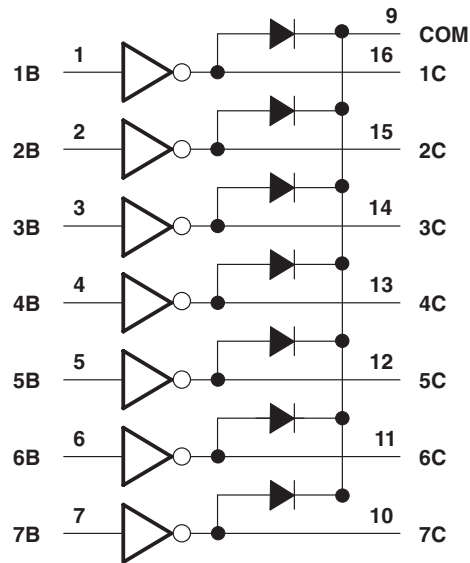

SCHEMATICS (EACH DARLINGTON PAIR)

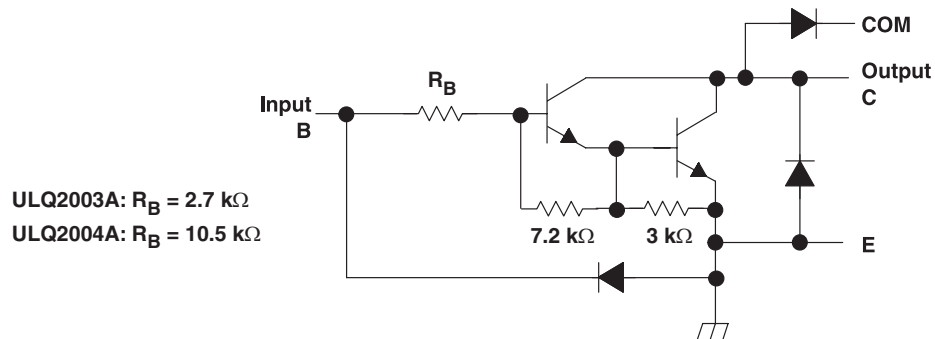

- A. All resistor values shown are nominal.
- B. The collector-emitter diode is a parasitic structure and should not be used to conduct current. If the collector(s) go below ground an external Schottky diode should be added to clamp negative undershoots.

ABSOLUTE MAXIMUM RATINGS⁽¹⁾

at 25°C free-air temperature (unless otherwise noted)

		MIN	MAX	UNIT	
V _{CC}	Collector-emitter voltage		50	V	
	Clamp diode reverse voltage ⁽²⁾		50	V	
V _I	Input voltage ⁽²⁾		30	V	
	Peak collector current	See Figure 14	500	mA	
I _{OK}	Output clamp current		500	mA	
	Total emitter-terminal current		-2.5	A	
P _D	Continuous total power dissipation	See <i>Dissipation Ratings Table</i>			
T _A	Operating free-air temperature range	ULQ200xAT	-40	105	°C
		ULQ200xAQ	-40	125	
θ _{JA}	Package thermal impedance ^{(3) (4)}	D package		73	°C/W
		PW package		108	
T _{stg}	Storage temperature range		-65	150	°C

- (1) Stresses beyond those listed under "absolute maximum ratings" may cause permanent damage to the device. These are stress ratings only, and functional operation of the device at these or any other conditions beyond those indicated under "recommended operating conditions" is not implied. Exposure to absolute-maximum-rated conditions for extended periods may affect device reliability.
- (2) All voltage values are with respect to the emitter/substrate terminal E, unless otherwise noted.
- (3) Maximum power dissipation is a function of T_{J(max)}, θ_{JA}, and T_A. The maximum allowable power dissipation at any allowable ambient temperature is P_D = (T_{J(max)} - T_A)/θ_{JA}. Operating at the absolute maximum T_J of 150°C can affect reliability.
- (4) The package thermal impedance is calculated in accordance with JESD 51-7.

DISSIPATION RATINGS

PACKAGE	T _A = 25°C POWER RATING	DERATING FACTOR ABOVE T _A = 25°C	T _A = 85°C POWER RATING	T _A = 105°C POWER RATING	T _A = 125°C POWER RATING
D	950 mW	7.6 mW/°C	494 mW	342 mW	190 mW

ELECTRICAL CHARACTERISTICS

over recommended operating conditions (unless otherwise noted)

PARAMETER	TEST FIGURE	TEST CONDITIONS		ULQ2003AT			ULQ2003AQ			ULQ2004AT			UNIT
				MIN	TYP	MAX	MIN	TYP	MAX	MIN	TYP	MAX	
$V_{I(on)}$ On-state input voltage	Figure 6	$V_{CE} = 2\text{ V}$	$I_C = 125\text{ mA}$									5	V
			$I_C = 200\text{ mA}$		2.7		2.7					6	
			$I_C = 250\text{ mA}$		2.9		2.9						
			$I_C = 275\text{ mA}$									7	
			$I_C = 300\text{ mA}$			3		3					
			$I_C = 350\text{ mA}$									8	
$V_{CE(sat)}$ Collector-emitter saturation voltage	Figure 5		$I_I = 250\text{ }\mu\text{A}$, $I_C = 100\text{ mA}$	0.9	1.2		1	1.3		0.9	1.1		V
			$I_I = 350\text{ }\mu\text{A}$, $I_C = 200\text{ mA}$		1	1.4		1	1.5		1	1.3	
			$I_I = 500\text{ }\mu\text{A}$, $I_C = 350\text{ mA}$		1.2	1.7		1.2	1.8		1.2	1.6	
I_{CEX} Collector cutoff current	Figure 1	$V_{CE} = 50\text{ V}$, $I_I = 0$	$T_A = 25^\circ\text{C}$			100			100			50	μA
			$T_A = 105^\circ\text{C}$			165							
	Figure 2	$V_{CE} = 50\text{ V}$	$I_I = 0$									100	
			$V_I = 1\text{ V}$									500	
V_F Clamp forward voltage	Figure 8	$I_F = 350\text{ mA}$			1.7	2.2		1.7	2.2		1.7	2.1	V
$I_{I(off)}$ Off-state input current	Figure 3	$V_{CE} = 50\text{ V}$, $I_C = 500\text{ }\mu\text{A}$		30	65		30	65		50	65	μA	
I_I Input current	Figure 4	$V_I = 3.85\text{ V}$			0.93	1.35		0.93	1.35				mA
		$V_I = 5\text{ V}$									0.35	0.5	
		$V_I = 12\text{ V}$										1	
I_R Clamp reverse current	Figure 7	$V_R = 50\text{ V}$	$T_A = 25^\circ\text{C}$			100			100			50	μA
						100			100			100	
C_i Input capacitance		$V_I = 0$,	$f = 1\text{ MHz}$		15	25		15	25		15	25	pF

SWITCHING CHARACTERISTICS

over recommended operating conditions (unless otherwise noted)

PARAMETER	TEST CONDITIONS	ULQ2003A, ULQ2004A			UNIT
		MIN	TYP	MAX	
t_{PLH} Propagation delay time, low- to high-level output	See Figure 9		1	10	μs
t_{PHL} Propagation delay time, high- to low-level output	See Figure 9		1	10	μs
V_{OH} High-level output voltage after switching	$V_S = 50\text{ V}$, $I_O = 300\text{ mA}$, See Figure 10		$V_S - 500$		mV

PARAMETER MEASUREMENT INFORMATION

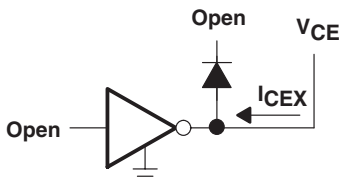

Figure 1. I_{CEX} Test Circuit

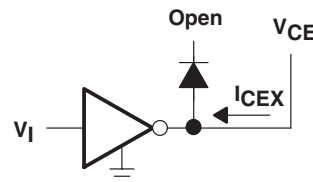

Figure 2. I_{CEX} Test Circuit

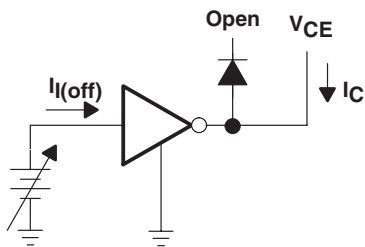

Figure 3. $I_{I(off)}$ Test Circuit

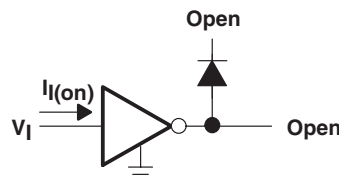

Figure 4. I_I Test Circuit

C. I_I is fixed for measuring $V_{CE(sat)}$, variable for measuring h_{FE} .

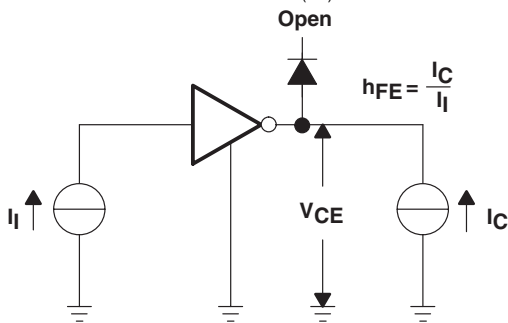

Figure 5. h_{FE} , $V_{CE(sat)}$ Test Circuit

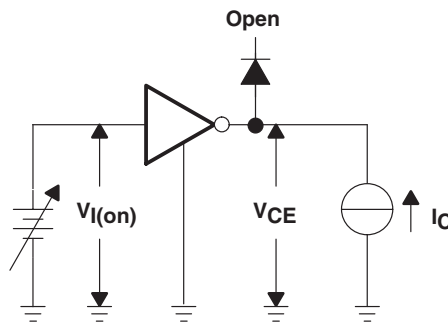

Figure 6. $V_{I(on)}$ Test Circuit

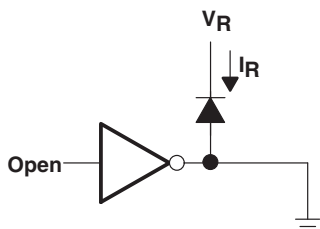

Figure 7. I_R Test Circuit

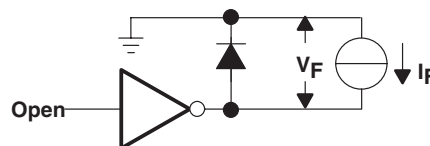
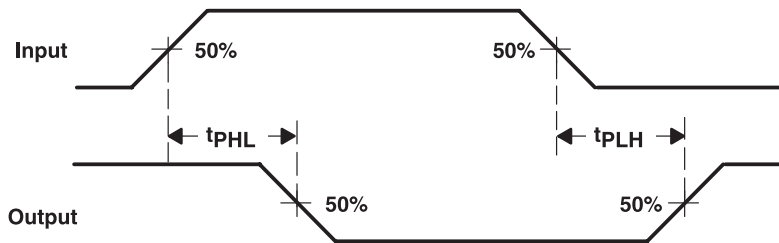

Figure 8. V_F Test Circuit



VOLTAGE WAVEFORMS

Figure 9. Propagation Delay-Time Waveforms

PARAMETER MEASUREMENT INFORMATION (continued)

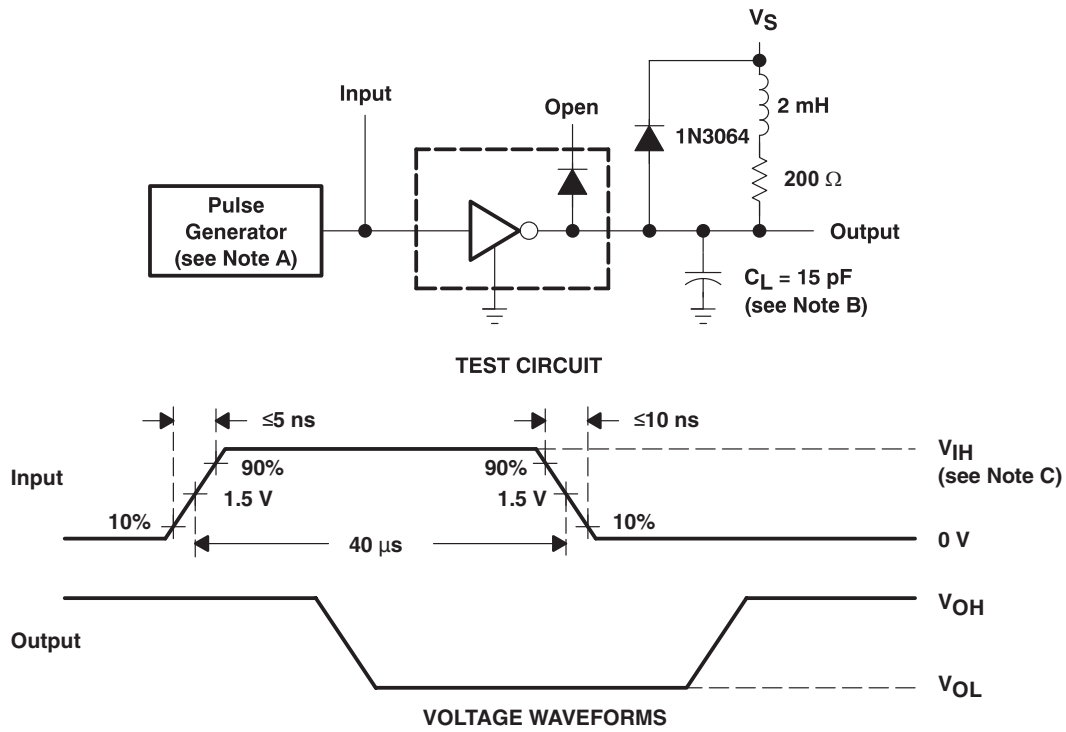

- A. The pulse generator has the following characteristics: PRR = 12.5 kHz, $Z_O = 50 \Omega$.
- B. C_L includes probe and jig capacitance.
- C. For testing the ULQ2003A, $V_{IH} = 3 \text{ V}$; for the ULQ2004A, $V_{IH} = 8 \text{ V}$.

Figure 10. Latch-Up Test Circuit and Voltage Waveforms

TYPICAL CHARACTERISTICS

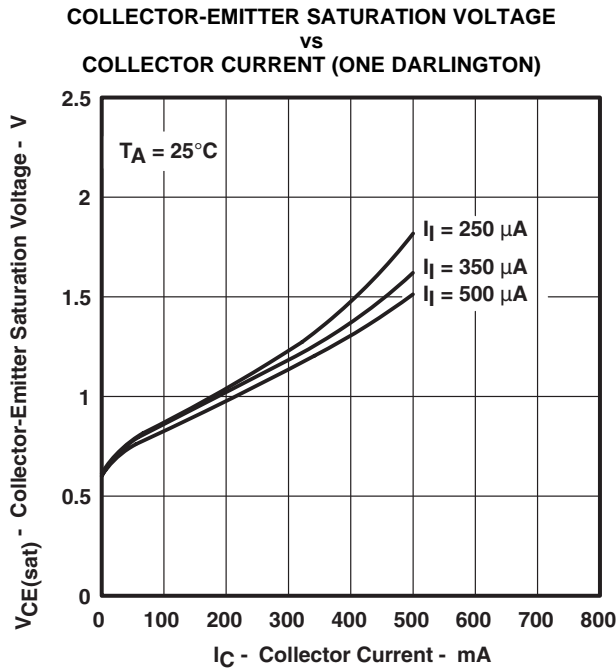

Figure 11.

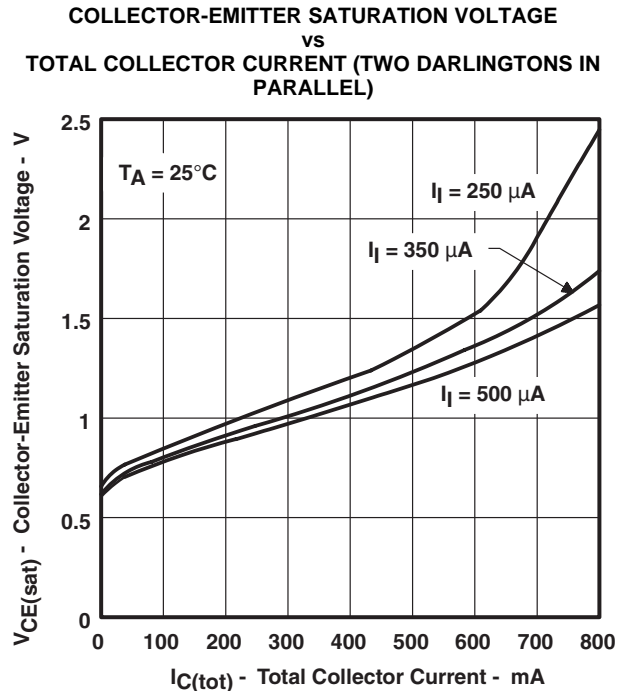

Figure 12.

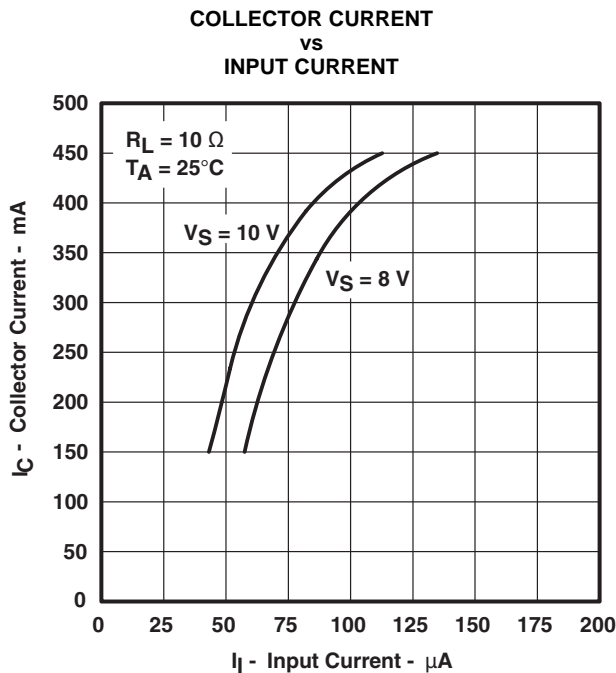

Figure 13.

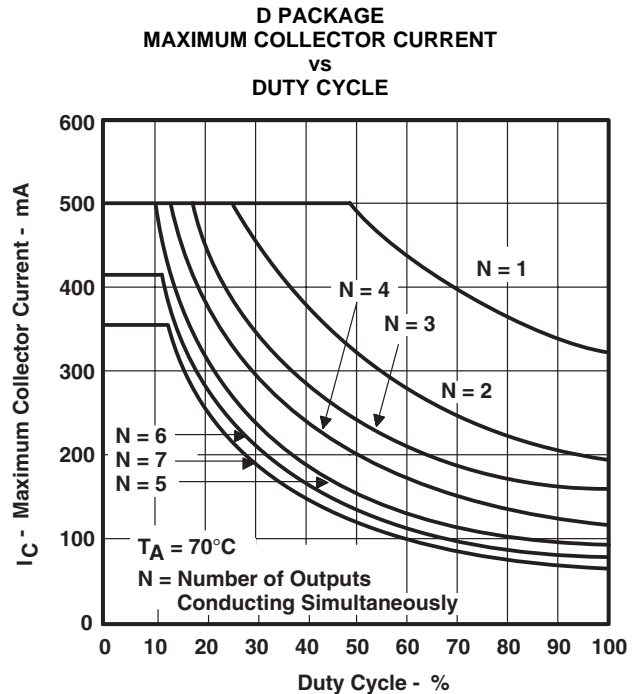

Figure 14.

APPLICATION INFORMATION

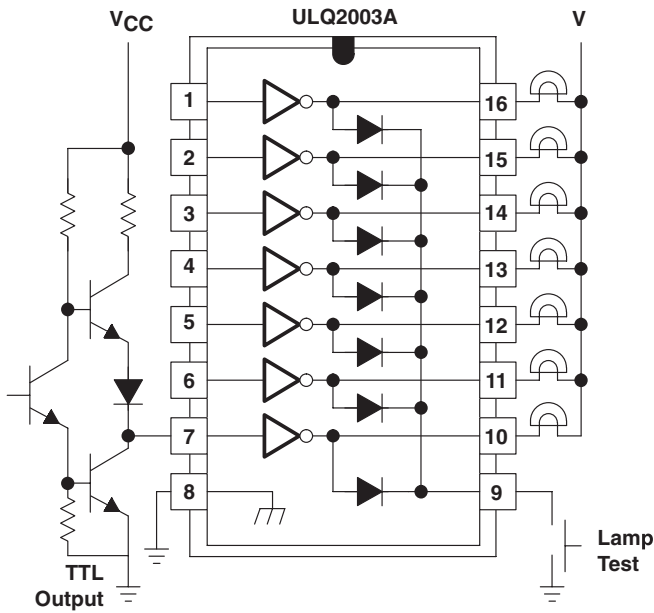

Figure 15. TTL to Load

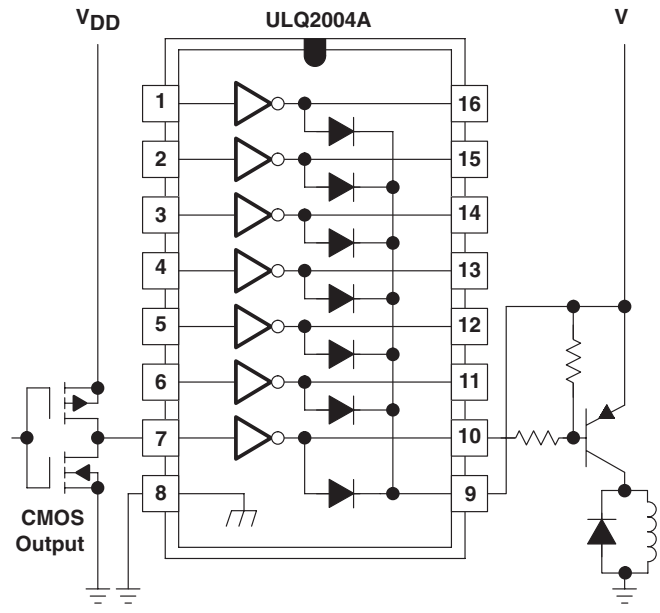

Figure 16. Buffer for Higher Current Loads

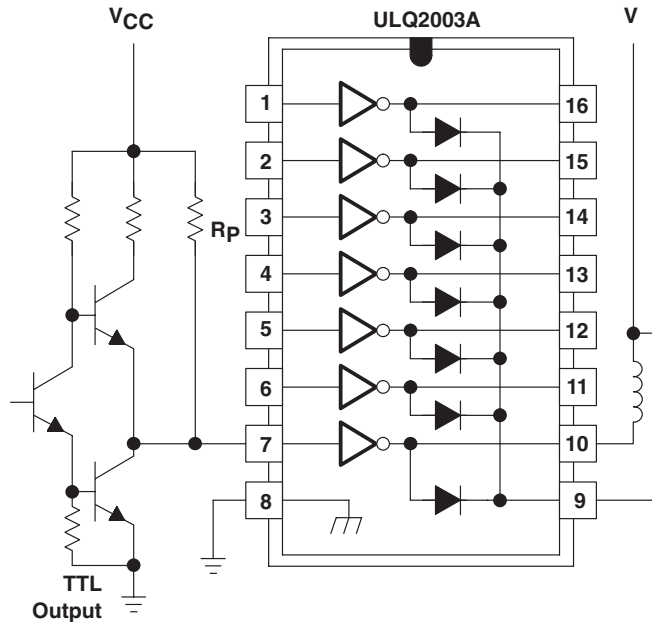

Figure 17. Use of Pullup Resistors to Increase Drive Current

PACKAGING INFORMATION

Orderable Device	Status ⁽¹⁾	Package Type	Package Drawing	Pins	Package Qty	Eco Plan ⁽²⁾	Lead/Ball Finish	MSL Peak Temp ⁽³⁾
ULQ2003AQDRQ1	ACTIVE	SOIC	D	16	2500	Green (RoHS & no Sb/Br)	CU NIPDAU	Level-1-260C-UNLIM
ULQ2003ATDG4Q1	ACTIVE	SOIC	D	16	40	Green (RoHS & no Sb/Br)	CU NIPDAU	Level-1-260C-UNLIM
ULQ2003ATDQ1	ACTIVE	SOIC	D	16	40	Green (RoHS & no Sb/Br)	CU NIPDAU	Level-1-260C-UNLIM
ULQ2003ATDRG4Q1	ACTIVE	SOIC	D	16	2500	Green (RoHS & no Sb/Br)	CU NIPDAU	Level-1-260C-UNLIM
ULQ2003ATDRQ1	ACTIVE	SOIC	D	16	2500	Green (RoHS & no Sb/Br)	CU NIPDAU	Level-1-260C-UNLIM
ULQ2003ATPWRQ1	ACTIVE	TSSOP	PW	16	2500	Green (RoHS & no Sb/Br)	CU NIPDAU	Level-1-260C-UNLIM
ULQ2004ATDRG4Q1	ACTIVE	SOIC	D	16	2500	Green (RoHS & no Sb/Br)	CU NIPDAU	Level-1-260C-UNLIM
ULQ2004ATDRQ1	ACTIVE	SOIC	D	16	2500	Green (RoHS & no Sb/Br)	CU NIPDAU	Level-1-260C-UNLIM

⁽¹⁾ The marketing status values are defined as follows:

ACTIVE: Product device recommended for new designs.

LIFEBUY: TI has announced that the device will be discontinued, and a lifetime-buy period is in effect.

NRND: Not recommended for new designs. Device is in production to support existing customers, but TI does not recommend using this part in a new design.

PREVIEW: Device has been announced but is not in production. Samples may or may not be available.

OBSOLETE: TI has discontinued the production of the device.

⁽²⁾ Eco Plan - The planned eco-friendly classification: Pb-Free (RoHS), Pb-Free (RoHS Exempt), or Green (RoHS & no Sb/Br) - please check <http://www.ti.com/productcontent> for the latest availability information and additional product content details.

TBD: The Pb-Free/Green conversion plan has not been defined.

Pb-Free (RoHS): TI's terms "Lead-Free" or "Pb-Free" mean semiconductor products that are compatible with the current RoHS requirements for all 6 substances, including the requirement that lead not exceed 0.1% by weight in homogeneous materials. Where designed to be soldered at high temperatures, TI Pb-Free products are suitable for use in specified lead-free processes.

Pb-Free (RoHS Exempt): This component has a RoHS exemption for either 1) lead-based flip-chip solder bumps used between the die and package, or 2) lead-based die adhesive used between the die and leadframe. The component is otherwise considered Pb-Free (RoHS compatible) as defined above.

Green (RoHS & no Sb/Br): TI defines "Green" to mean Pb-Free (RoHS compatible), and free of Bromine (Br) and Antimony (Sb) based flame retardants (Br or Sb do not exceed 0.1% by weight in homogeneous material)

⁽³⁾ MSL, Peak Temp. -- The Moisture Sensitivity Level rating according to the JEDEC industry standard classifications, and peak solder temperature.

Important Information and Disclaimer: The information provided on this page represents TI's knowledge and belief as of the date that it is provided. TI bases its knowledge and belief on information provided by third parties, and makes no representation or warranty as to the accuracy of such information. Efforts are underway to better integrate information from third parties. TI has taken and continues to take reasonable steps to provide representative and accurate information but may not have conducted destructive testing or chemical analysis on incoming materials and chemicals. TI and TI suppliers consider certain information to be proprietary, and thus CAS numbers and other limited information may not be available for release.

In no event shall TI's liability arising out of such information exceed the total purchase price of the TI part(s) at issue in this document sold by TI to Customer on an annual basis.

OTHER QUALIFIED VERSIONS OF ULQ2003A-Q1, ULQ2004A-Q1 :

- Catalog: [ULQ2003A](#), [ULQ2004A](#)

NOTE: Qualified Version Definitions:

- Catalog - TI's standard catalog product

TAPE AND REEL INFORMATION

QUADRANT ASSIGNMENTS FOR PIN 1 ORIENTATION IN TAPE

*All dimensions are nominal

Device	Package Type	Package Drawing	Pins	SPQ	Reel Diameter (mm)	Reel Width W1 (mm)	A0 (mm)	B0 (mm)	K0 (mm)	P1 (mm)	W (mm)	Pin1 Quadrant
ULQ2003ATPWRQ1	TSSOP	PW	16	2500	330.0	12.4	6.9	5.6	1.6	8.0	12.0	Q1

TAPE AND REEL BOX DIMENSIONS

*All dimensions are nominal

Device	Package Type	Package Drawing	Pins	SPQ	Length (mm)	Width (mm)	Height (mm)
ULQ2003ATPWRQ1	TSSOP	PW	16	2500	346.0	346.0	29.0

D (R-PDSO-G16)

PLASTIC SMALL OUTLINE



- NOTES:
- A. All linear dimensions are in inches (millimeters).
 - B. This drawing is subject to change without notice.
 - C. Body length does not include mold flash, protrusions, or gate burrs. Mold flash, protrusions, or gate burrs shall not exceed 0.006 (0,15) each side.
 - D. Body width does not include interlead flash. Interlead flash shall not exceed 0.017 (0,43) each side.
 - E. Reference JEDEC MS-012 variation AC.

D (R-PDSO-G16)

PLASTIC SMALL OUTLINE

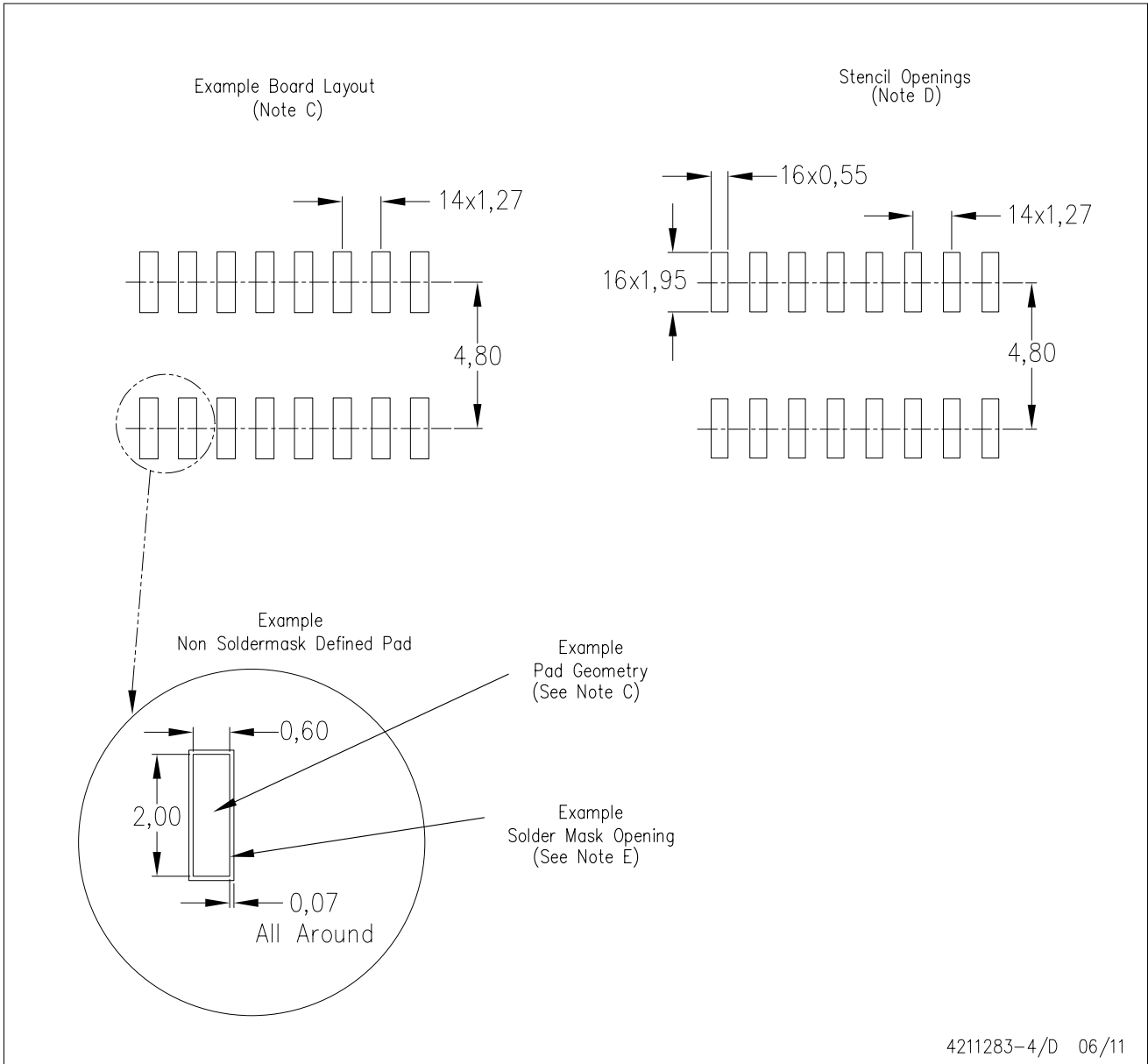



- NOTES:
- A. All linear dimensions are in millimeters.
 - B. This drawing is subject to change without notice.
 - C. Publication IPC-7351 is recommended for alternate designs.
 - D. Laser cutting apertures with trapezoidal walls and also rounding corners will offer better paste release. Customers should contact their board assembly site for stencil design recommendations. Refer to IPC-7525 for other stencil recommendations.
 - E. Customers should contact their board fabrication site for solder mask tolerances between and around signal pads.

PW (R-PDSO-G16)

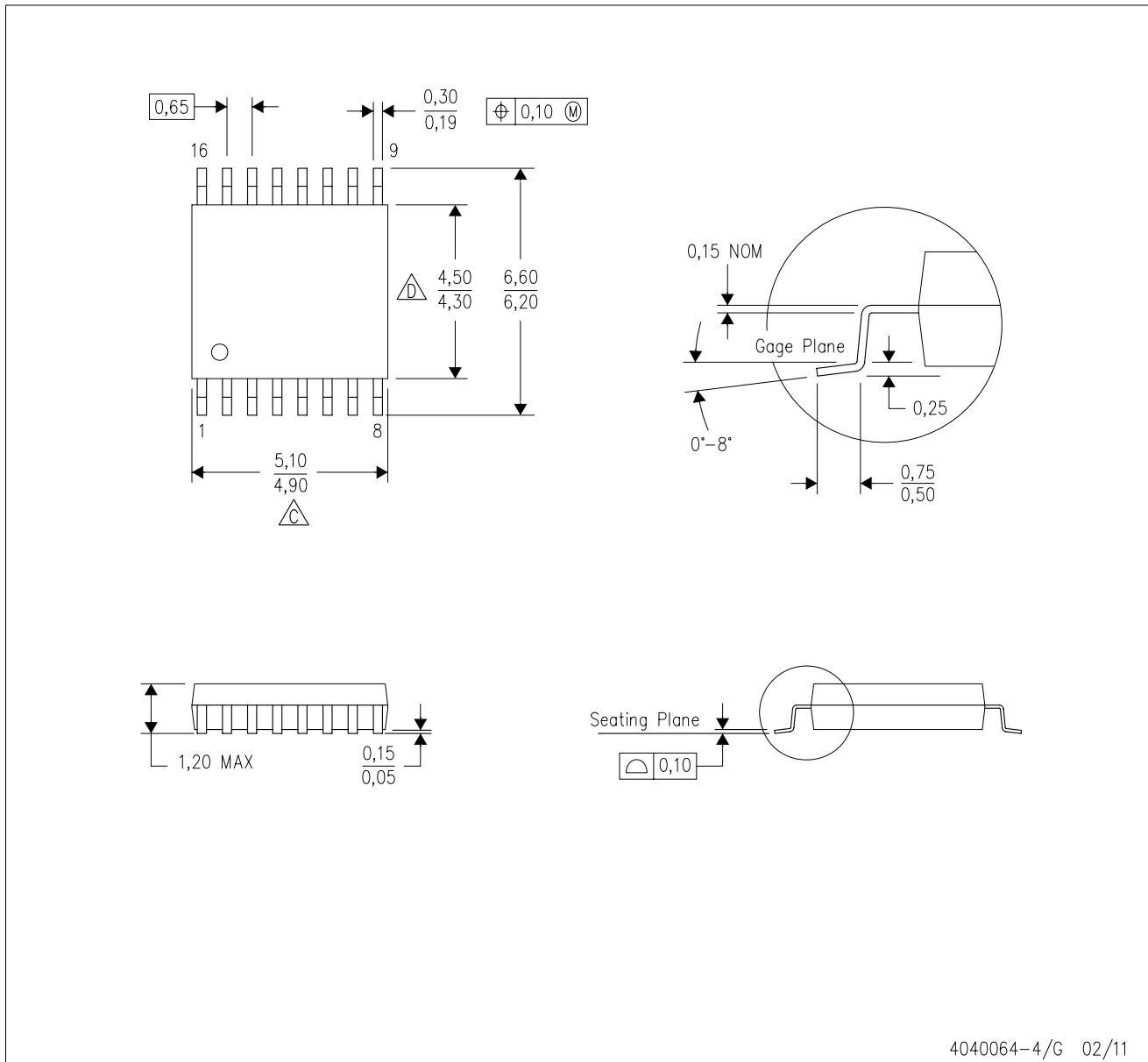
PLASTIC SMALL OUTLINE



4040064-4/G 02/11

- NOTES:
- A. All linear dimensions are in millimeters. Dimensioning and tolerancing per ASME Y14.5M-1994.
 - B. This drawing is subject to change without notice.
 -  Body length does not include mold flash, protrusions, or gate burrs. Mold flash, protrusions, or gate burrs shall not exceed 0,15 each side.
 -  Body width does not include interlead flash. Interlead flash shall not exceed 0,25 each side.
 - E. Falls within JEDEC MO-153

PW (R-PDSO-G16)

PLASTIC SMALL OUTLINE

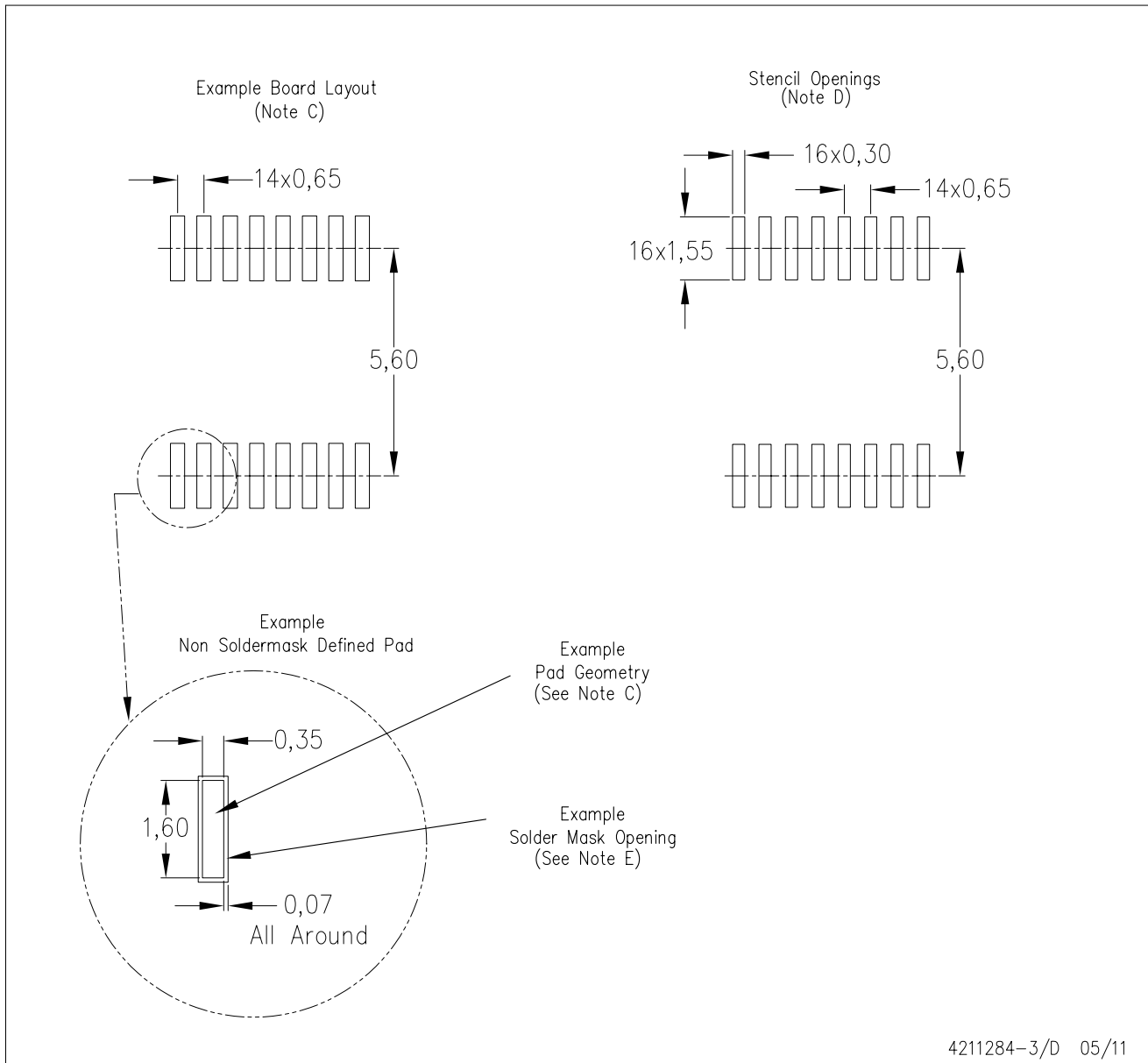

- NOTES:
- All linear dimensions are in millimeters.
 - This drawing is subject to change without notice.
 - Publication IPC-7351 is recommended for alternate designs.
 - Laser cutting apertures with trapezoidal walls and also rounding corners will offer better paste release. Customers should contact their board assembly site for stencil design recommendations. Refer to IPC-7525 for other stencil recommendations.
 - Customers should contact their board fabrication site for solder mask tolerances between and around signal pads.

IMPORTANT NOTICE

Texas Instruments Incorporated and its subsidiaries (TI) reserve the right to make corrections, modifications, enhancements, improvements, and other changes to its products and services at any time and to discontinue any product or service without notice. Customers should obtain the latest relevant information before placing orders and should verify that such information is current and complete. All products are sold subject to TI's terms and conditions of sale supplied at the time of order acknowledgment.

TI warrants performance of its hardware products to the specifications applicable at the time of sale in accordance with TI's standard warranty. Testing and other quality control techniques are used to the extent TI deems necessary to support this warranty. Except where mandated by government requirements, testing of all parameters of each product is not necessarily performed.

TI assumes no liability for applications assistance or customer product design. Customers are responsible for their products and applications using TI components. To minimize the risks associated with customer products and applications, customers should provide adequate design and operating safeguards.

TI does not warrant or represent that any license, either express or implied, is granted under any TI patent right, copyright, mask work right, or other TI intellectual property right relating to any combination, machine, or process in which TI products or services are used. Information published by TI regarding third-party products or services does not constitute a license from TI to use such products or services or a warranty or endorsement thereof. Use of such information may require a license from a third party under the patents or other intellectual property of the third party, or a license from TI under the patents or other intellectual property of TI.

Reproduction of TI information in TI data books or data sheets is permissible only if reproduction is without alteration and is accompanied by all associated warranties, conditions, limitations, and notices. Reproduction of this information with alteration is an unfair and deceptive business practice. TI is not responsible or liable for such altered documentation. Information of third parties may be subject to additional restrictions.

Resale of TI products or services with statements different from or beyond the parameters stated by TI for that product or service voids all express and any implied warranties for the associated TI product or service and is an unfair and deceptive business practice. TI is not responsible or liable for any such statements.

TI products are not authorized for use in safety-critical applications (such as life support) where a failure of the TI product would reasonably be expected to cause severe personal injury or death, unless officers of the parties have executed an agreement specifically governing such use. Buyers represent that they have all necessary expertise in the safety and regulatory ramifications of their applications, and acknowledge and agree that they are solely responsible for all legal, regulatory and safety-related requirements concerning their products and any use of TI products in such safety-critical applications, notwithstanding any applications-related information or support that may be provided by TI. Further, Buyers must fully indemnify TI and its representatives against any damages arising out of the use of TI products in such safety-critical applications.

TI products are neither designed nor intended for use in military/aerospace applications or environments unless the TI products are specifically designated by TI as military-grade or "enhanced plastic." Only products designated by TI as military-grade meet military specifications. Buyers acknowledge and agree that any such use of TI products which TI has not designated as military-grade is solely at the Buyer's risk, and that they are solely responsible for compliance with all legal and regulatory requirements in connection with such use.

TI products are neither designed nor intended for use in automotive applications or environments unless the specific TI products are designated by TI as compliant with ISO/TS 16949 requirements. Buyers acknowledge and agree that, if they use any non-designated products in automotive applications, TI will not be responsible for any failure to meet such requirements.

Following are URLs where you can obtain information on other Texas Instruments products and application solutions:

Products

Audio	www.ti.com/audio
Amplifiers	amplifier.ti.com
Data Converters	dataconverter.ti.com
DLP® Products	www.dlp.com
DSP	dsp.ti.com
Clocks and Timers	www.ti.com/clocks
Interface	interface.ti.com
Logic	logic.ti.com
Power Mgmt	power.ti.com
Microcontrollers	microcontroller.ti.com
RFID	www.ti-rfid.com
RF/IF and ZigBee® Solutions	www.ti.com/lprf

Applications

Communications and Telecom	www.ti.com/communications
Computers and Peripherals	www.ti.com/computers
Consumer Electronics	www.ti.com/consumer-apps
Energy and Lighting	www.ti.com/energy
Industrial	www.ti.com/industrial
Medical	www.ti.com/medical
Security	www.ti.com/security
Space, Avionics and Defense	www.ti.com/space-avionics-defense
Transportation and Automotive	www.ti.com/automotive
Video and Imaging	www.ti.com/video
Wireless	www.ti.com/wireless-apps

TI E2E Community Home Page

e2e.ti.com

Mailing Address: Texas Instruments, Post Office Box 655303, Dallas, Texas 75265
Copyright © 2011, Texas Instruments Incorporated